

Cascade Corporate Center  
Worthington, OH 43085

For Sale /  
For Lease



## Professional office suites with free athletic club

### Sale Price: Call agents

Cascade I: 130 E Wilson Bridge Rd  
Cascade II: 150 E Wilson Bridge Rd  
Cascade V: 250 E Wilson Bridge Rd

### Lease Rate: \$9.95 PSF Net

### 2024 Projected Operating Expenses:

Cascade I \$9.48 PSF  
Cascade II \$8.67 PSF  
Cascade V \$8.84 PSF

### Available Space:

996 RSF to 31,319 RSF

- Excellent Worthington location in close proximity to restaurants, services and shopping
- Convenient access to I-270, I-71, SR 315 and SR 23
- Lighted parking (4.1/1,000), vending area with seating, outdoor patio, storage, 24/7 key card access
- Athletic club in complex, free to tenants, offering handball/racquetball courts, exercise/cardio equipment, lockers, and sauna/showers
- Conference center for tenant use (accommodates 30)



Jackson Pulliam  
614.545.4097  
jpulliam@AlterraRE.com

Richard Conie  
614.545.4099  
rconie@AlterraRE.com

Alterra Real Estate  
614.365.9000  
www.AltterraRE.com

# Cascade Corporate Center

## Available Space for Lease

### Cascade I - 130 E Wilson Bridge Road

Floor	Suite	RSF	Comments
Terrace	75	1,225	
First	100	4,429	
	140	2,757	
	150	9,138	*Up to 17,995 SF on First Floor
Second	200	8,135	*Entire Second Floor Available: 16,995 SF
	210	3,085	
	250	5,674	*Large suite directly off lobby
Third	300	2,082	
	320	1,856	
	325	3,692	

\*Total Contiguous Available: 43,845 SF

### Cascade II - 150 E Wilson Bridge Road

Floor	Suite	RSF	Comments
First	120	1,566	
	160	3,455	
Second	210	1,373	
	235	1,536	*Available 10/2025
	250	2,591	
Third	320	4,414	
	330	1,002	

### Cascade V - 250 E Wilson Bridge Road

Floor	Suite	RSF	Comments
First	130	1,816	
	155	2,130	*Suites 155/175 Contiguous for 5,260 SF
	175	3,130	
	190	3,093	*Fully Furnished
Second	210	1,359	
	240	2,741	*Recently updated - can be combined with Suite 270
	270	1,760	

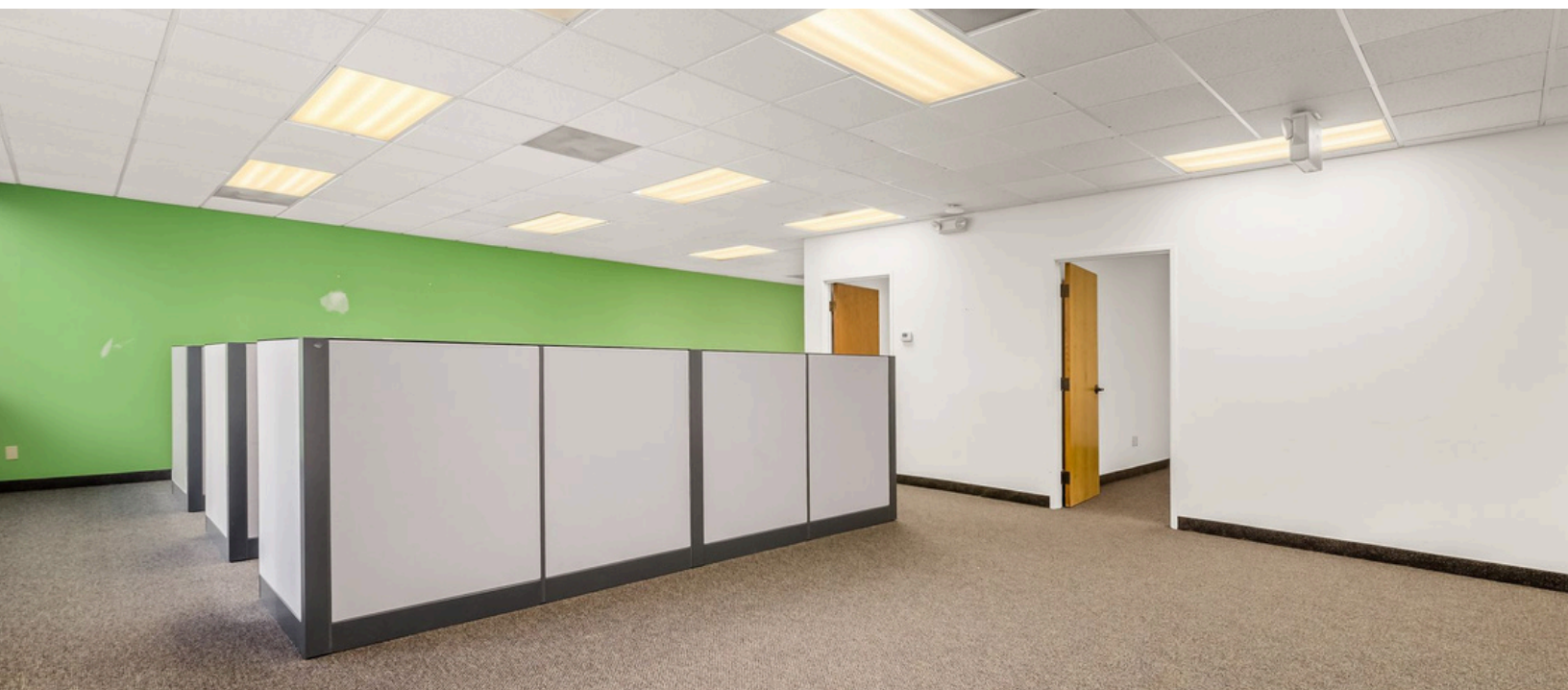





# Cascade Corporate Center Worthington, OH 43085

# For Lease

## Location Facts & Demographics

Demographics are determined by a 10 minute drive from 150 E Wilson Bridge Rd, Columbus, OH 43085



CITY, STATE  
**Columbus, OH**

POPULATION  
**131,621**

AVG. HHSIZE  
**2.34**

MEDIAN HH INCOME  
**\$68,103**

### HOME OWNERSHIP

Renters: **24,796**  
Owners: **31,773**

### EMPLOYMENT

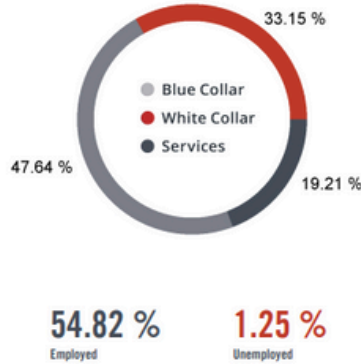

### EDUCATION

High School Grad: **19.08 %**  
Some College: **22.28 %**  
Associates: **6.71 %**  
Bachelors: **49.99 %**

### GENDER & AGE

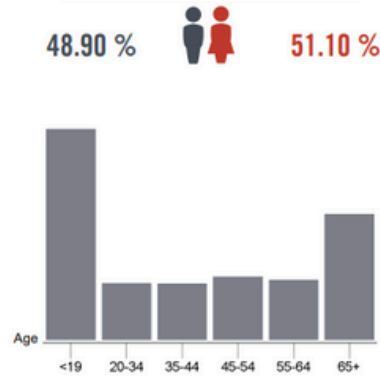

### RACE & ETHNICITY

White: **90.44 %**  
Asian: **3.17 %**  
Native American: **0.01 %**  
Pacific Islanders: **0.00 %**  
African-American: **2.75 %**  
Hispanic: **1.93 %**  
Two or More Races: **1.69 %**

### INCOME BY HOUSEHOLD

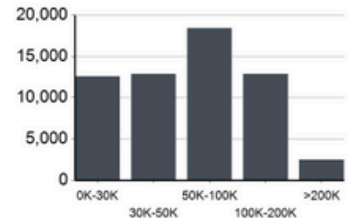

### HH SPENDING

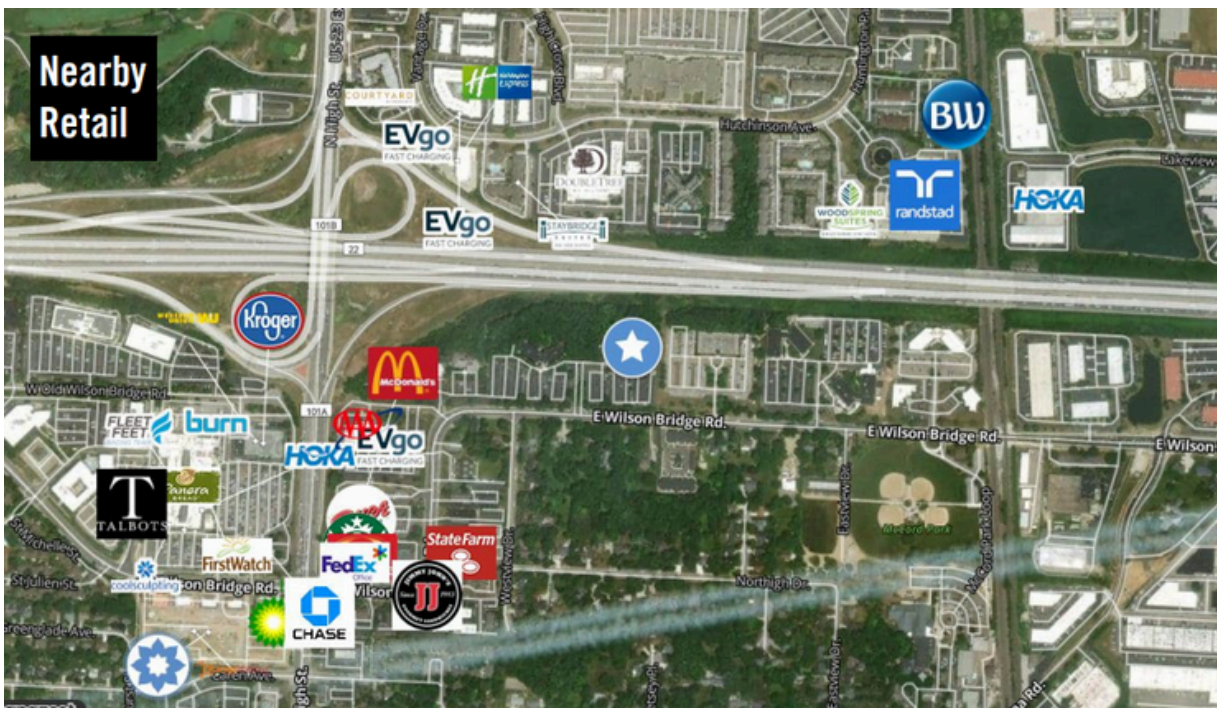
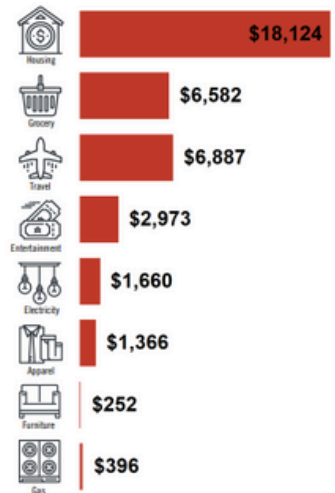

Jackson Pulliam  
614.545.4097  
jpulliam@AlterraRE.com

Richard Conie  
614.545.4099  
rconie@AlterraRE.com

Alterra Real Estate  
614.365.9000  
www.AltterraRE.com

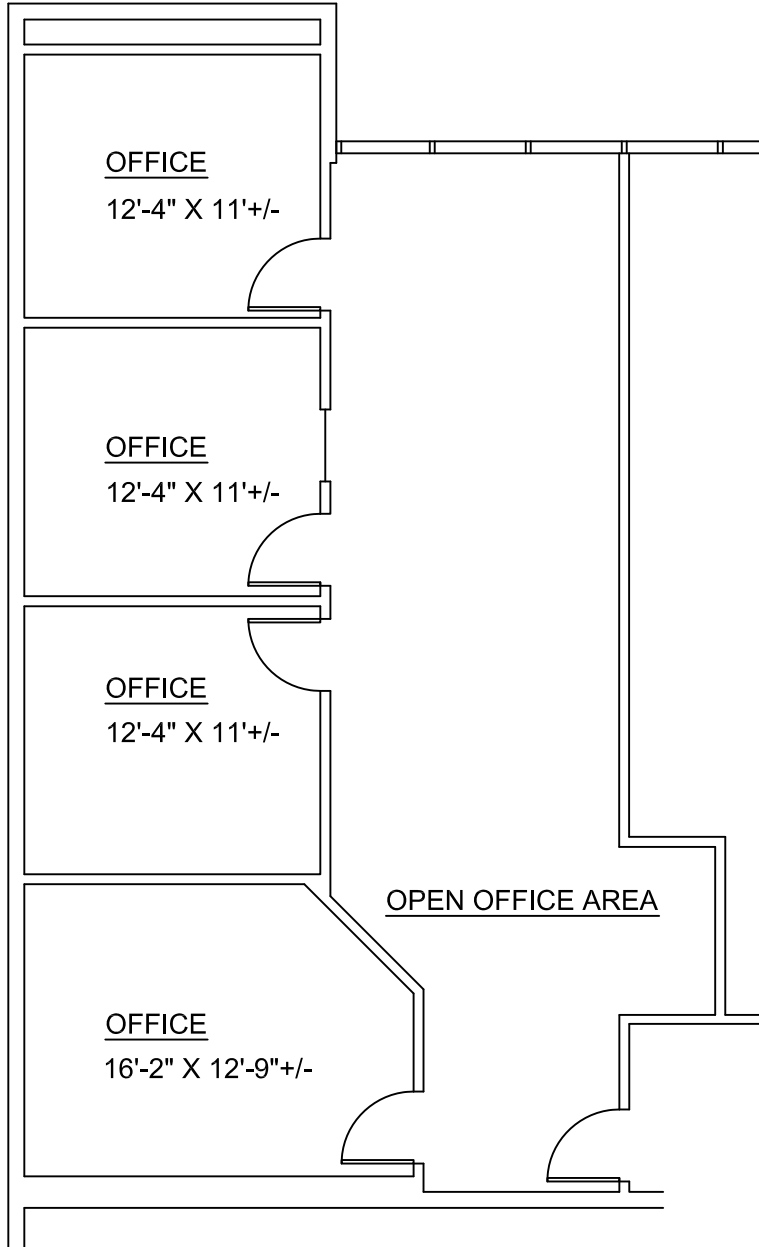

# Cascade I - Suite 75

1,225 Sq. Ft.    Scale 1/8" = 1' - 0"

## Cascade Corporate Center

130 East Wilson Bridge Road - Terrace Level  
 Worthington, Ohio

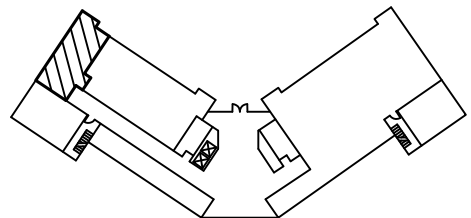

Terrace Level Key Plan

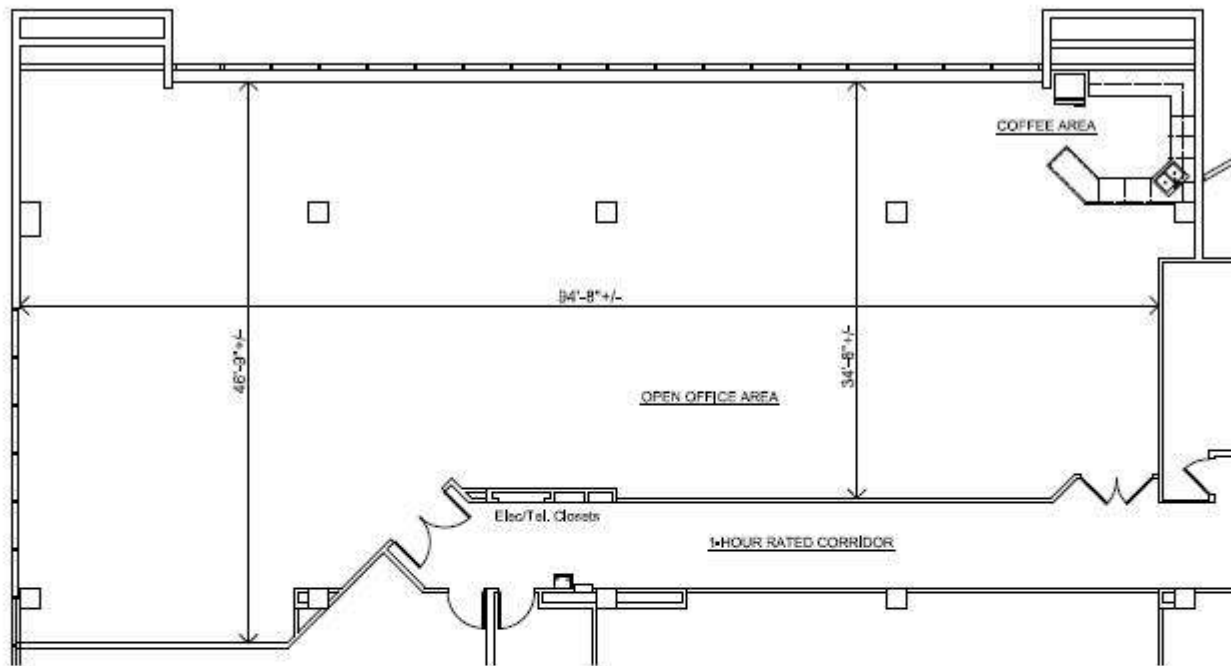

## Cascade I - Suite 100

4,429 Square Feet Available Not to Scale

## Cascade Corporate Center

130 East Wilson Bridge Road - First Floor  
Worthington, Ohio

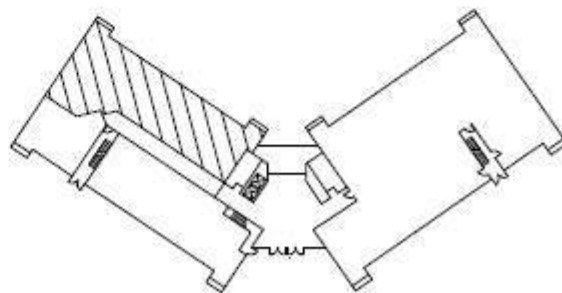

First Floor Key Plan



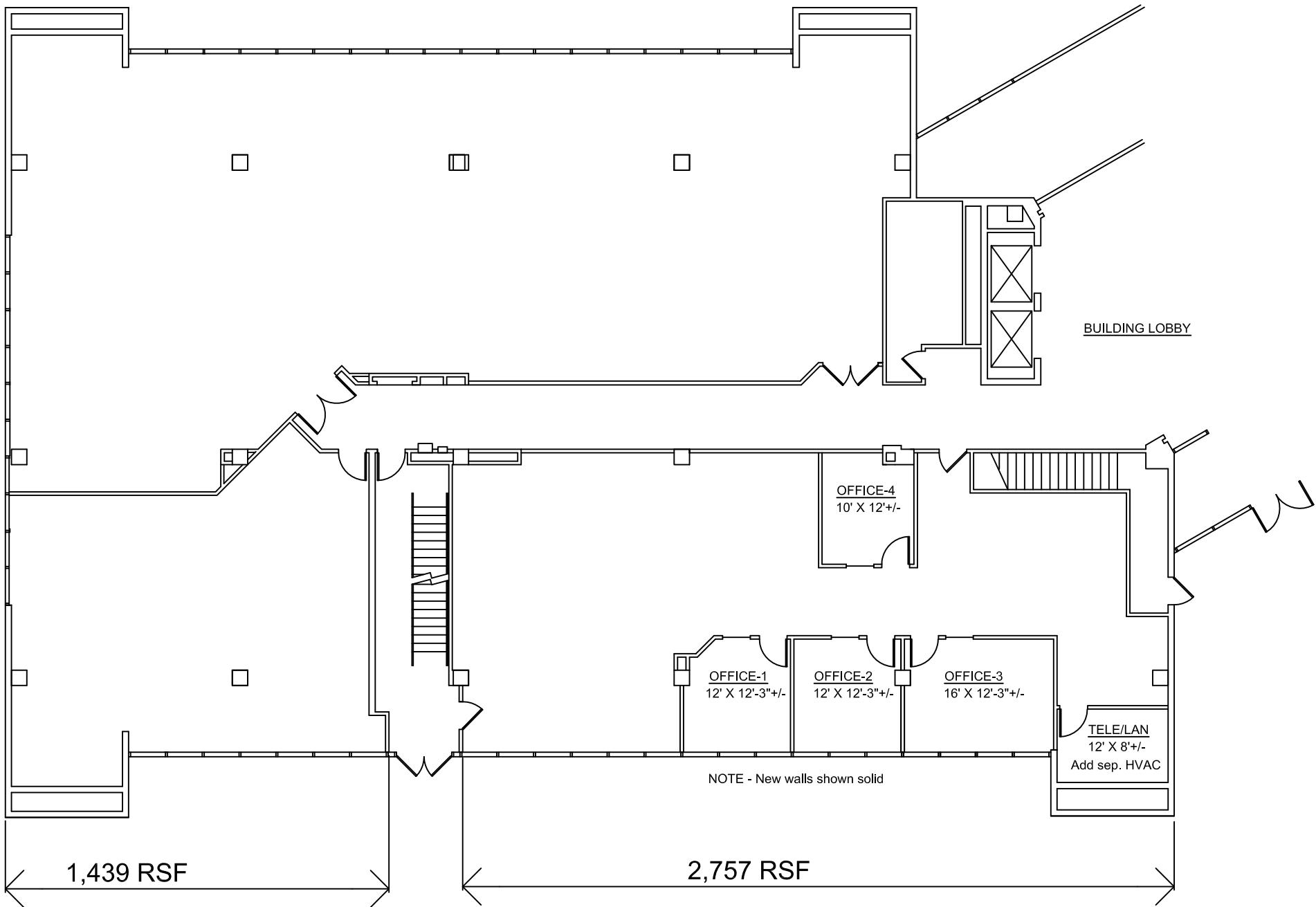

BUILDING LOBBY

OFFICE-4  
10' X 12'+/-

OFFICE-1  
12' X 12'-3"+/-

OFFICE-2  
12' X 12'-3"+/-

OFFICE-3  
16' X 12'-3"+/-

TELE/LAN  
12' X 8'+/-  
Add sep. HVAC

NOTE - New walls shown solid

1,439 RSF

2,757 RSF

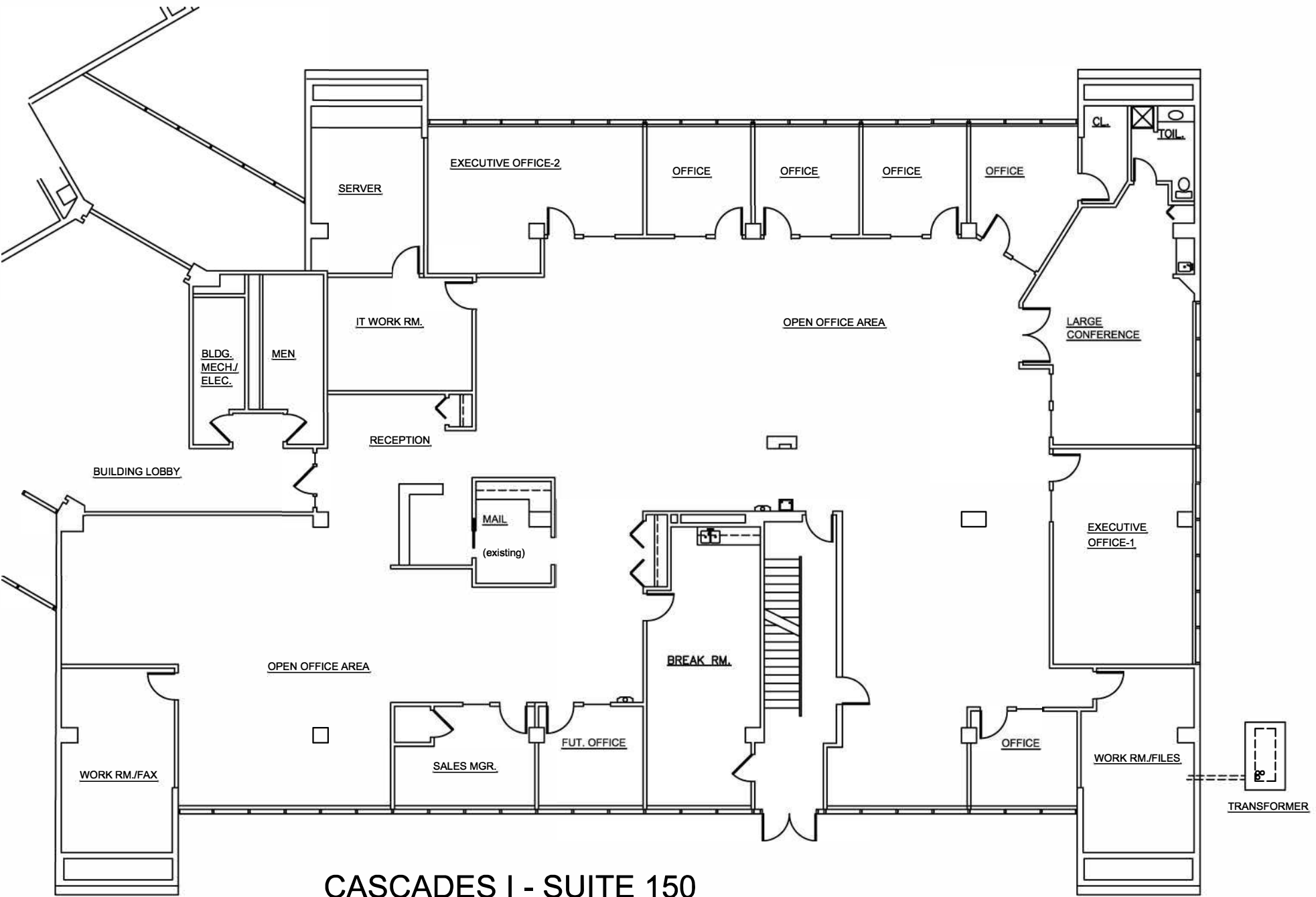

**CASCADES I - SUITE 150**  
**9,138 RSF**

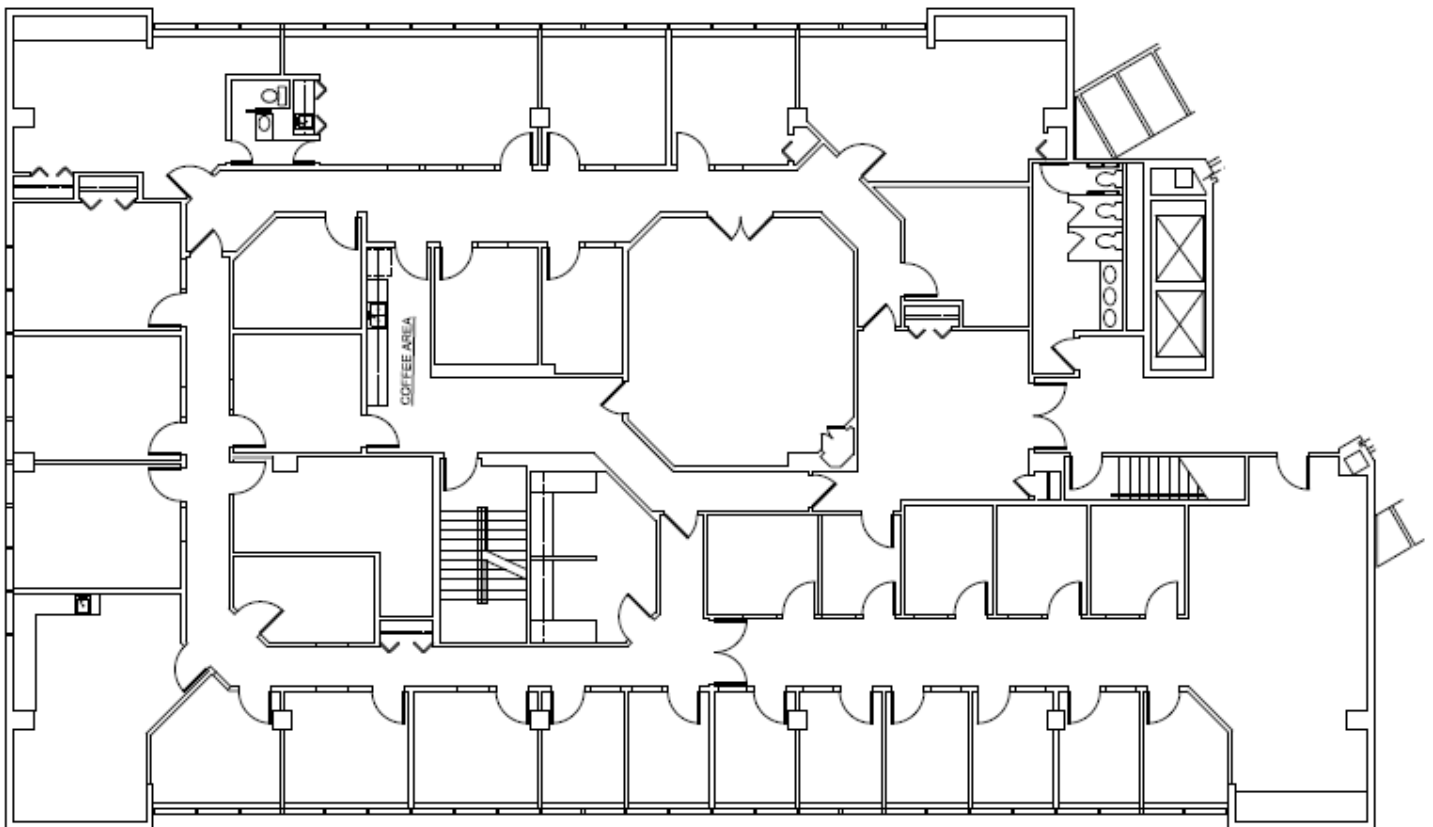

## Cascade I - Suite 200

8,135 Square Feet Available Not to Scale

## Cascade Corporate Center

130 East Wilson Bridge Road - Second Floor  
Worthington, Ohio

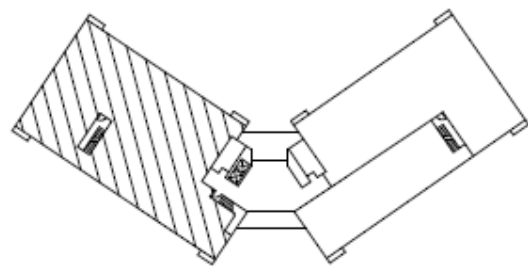

Second Floor Key Plan

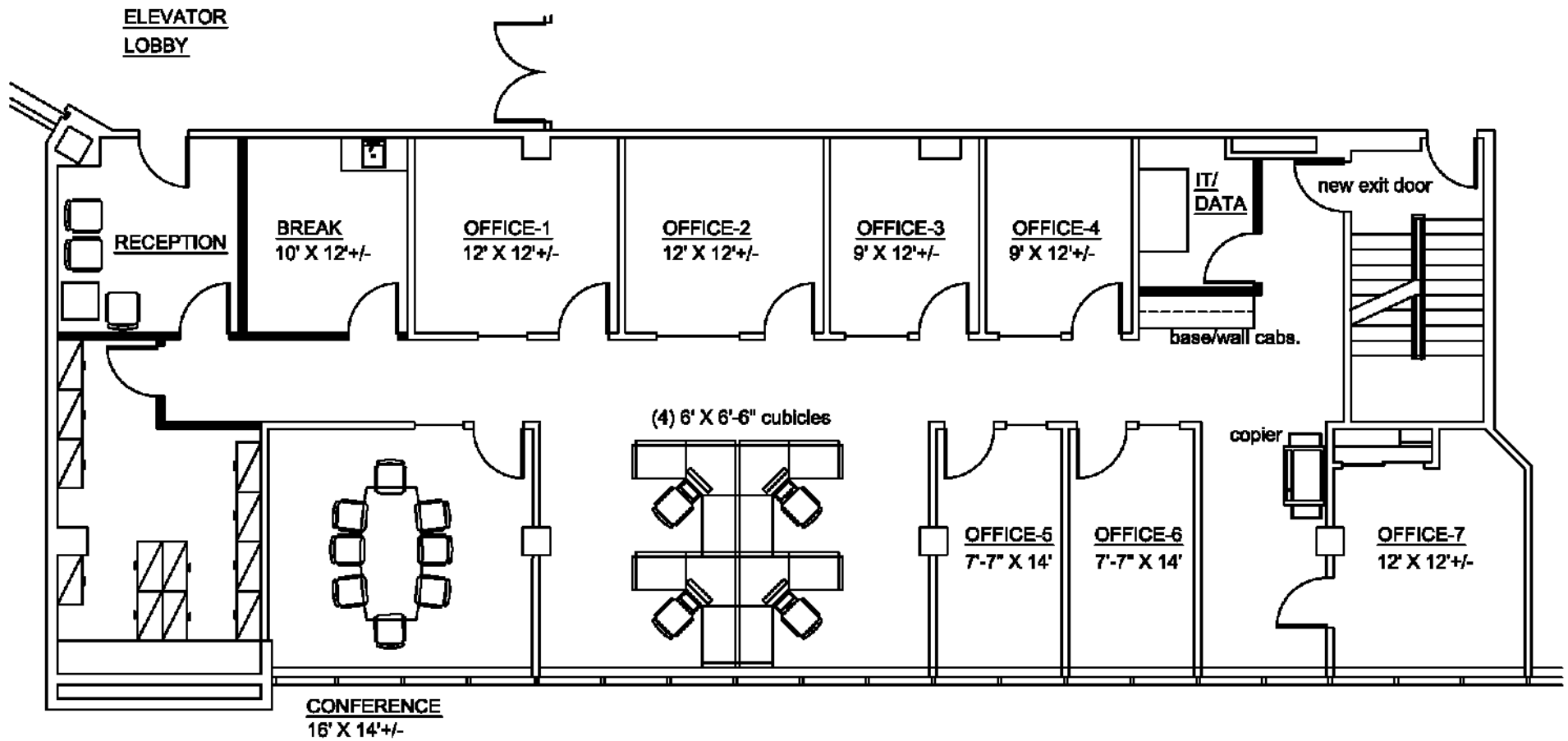

# Cascade I - Suite 210

3,085 Sq. Ft. Total Available    Not to Scale    09-27-17

## Cascade Corporate Center

130 East Wilson Bridge Road - Second Floor  
Worthington, Ohio

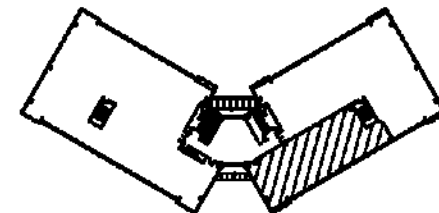

Second Floor Key Plan

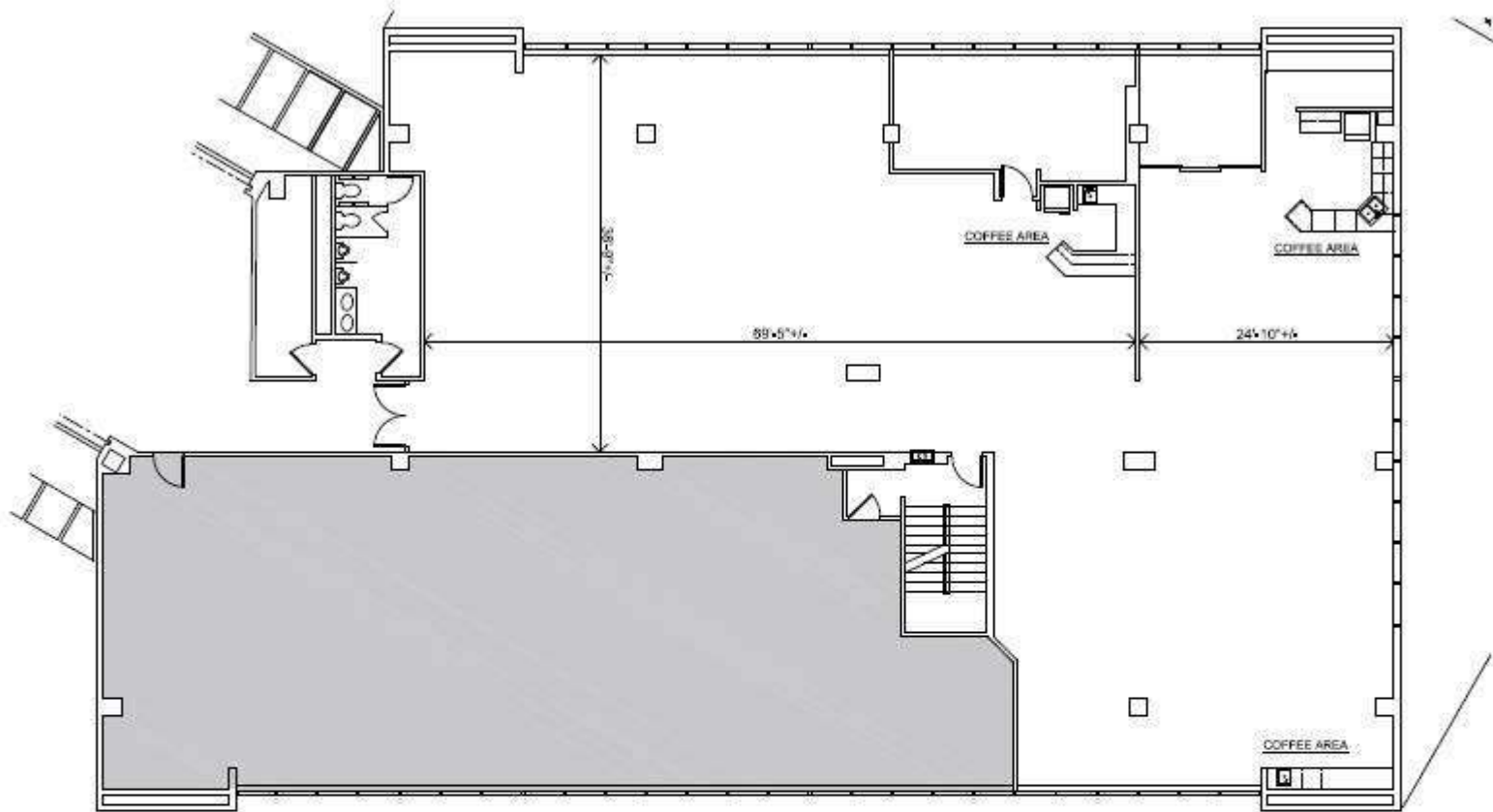

## Cascade I - Suite 250

5,674 Square Feet Available Not to Scale

## Cascade Corporate Center

130 East Wilson Bridge Road - Second Floor  
Worthington, Ohio

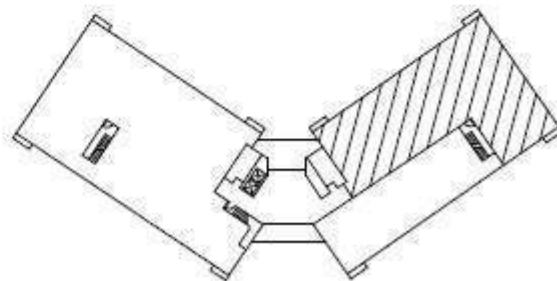

Second Floor Key Plan

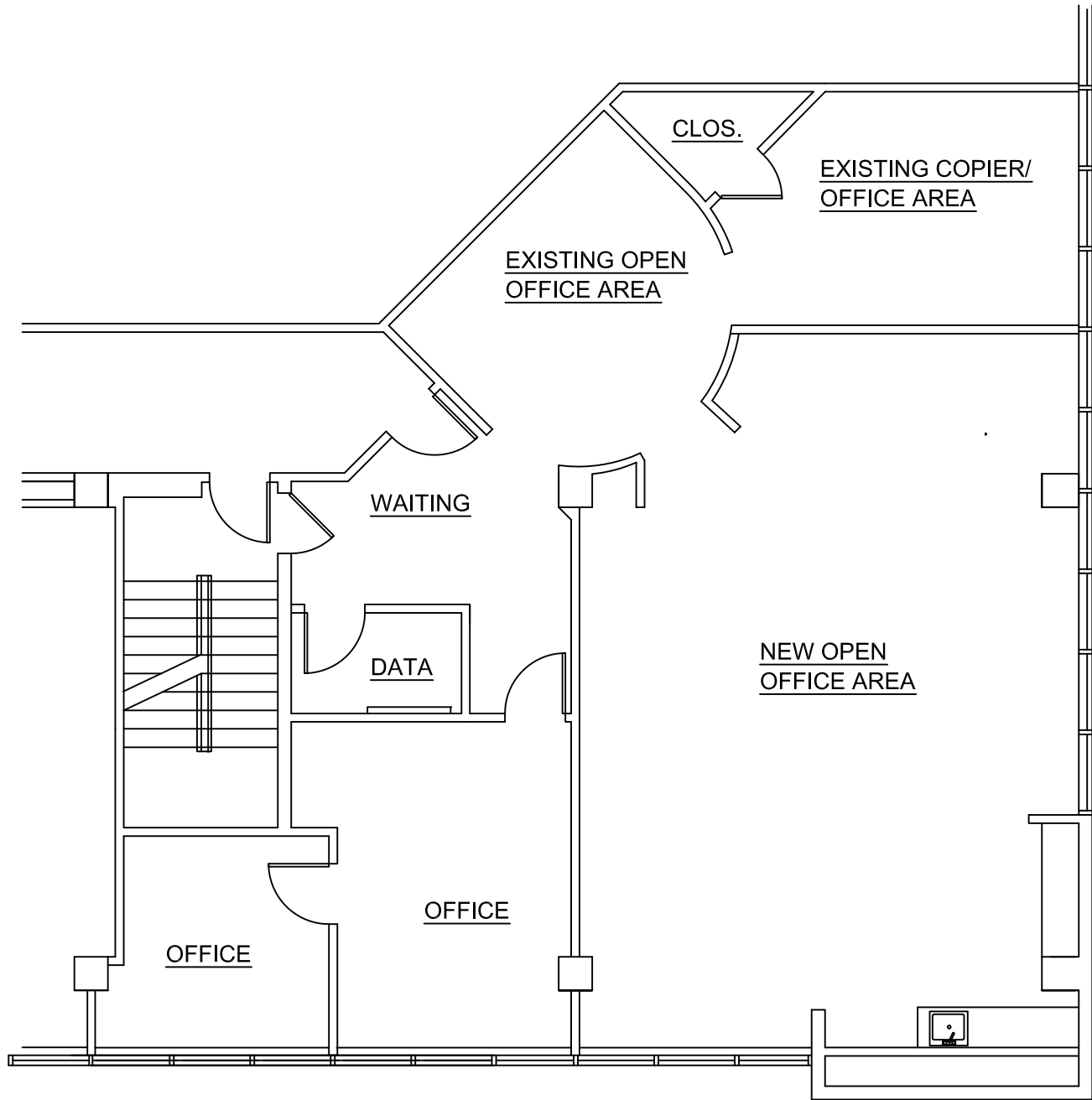

## HOME CARE NETWORK

CASCADE I  
130 E. WILSON BRIDGE RD. - SUITE 300  
WORTHINGTON, OHIO

2,082 RSF

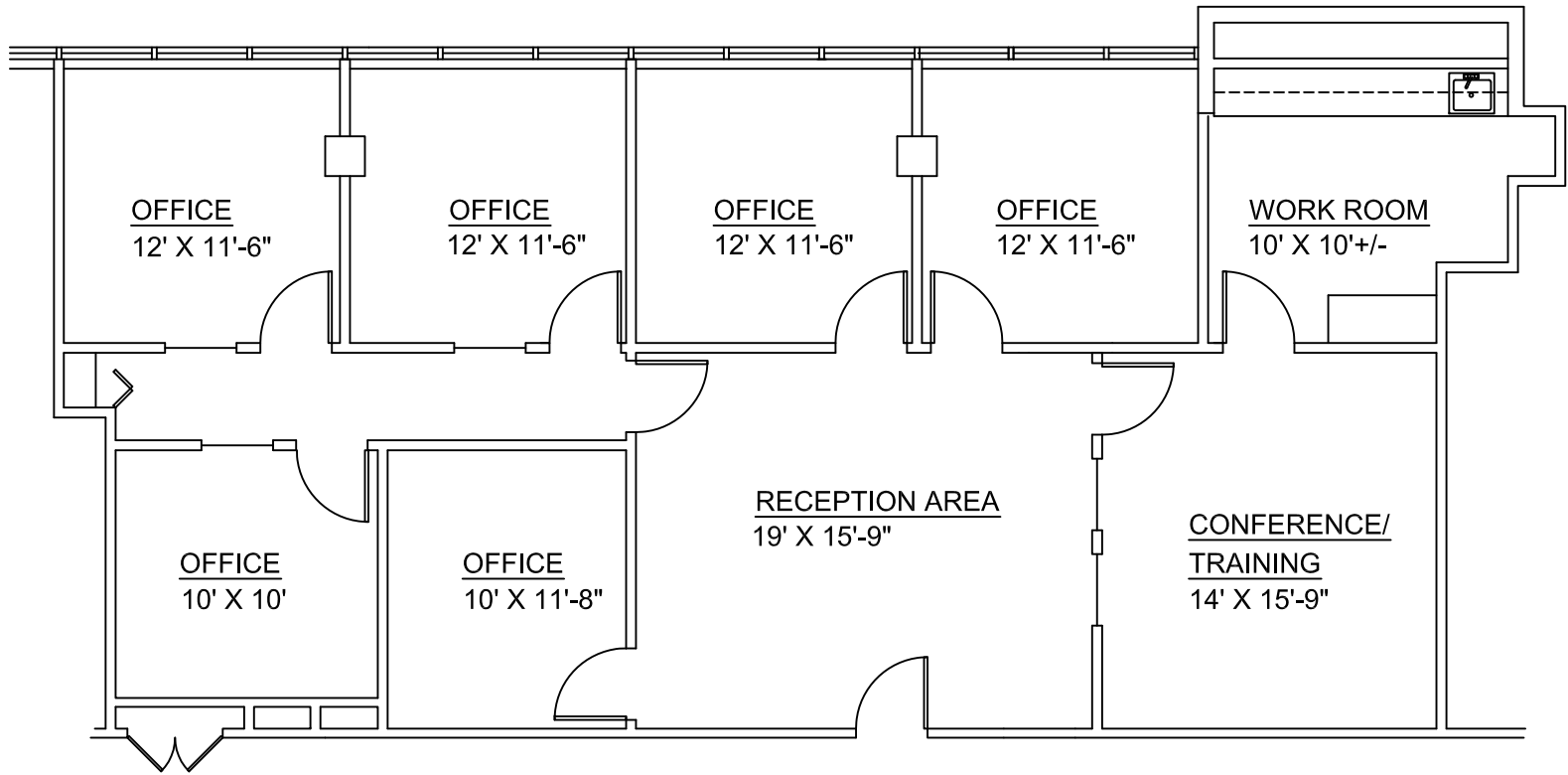

## Cascade I - Suite 320

1,856 Sq. Ft.    Scale 1/8" = 1' - 0"

## Cascade Corporate Center

130 East Wilson Bridge Road - Third Floor  
Worthington, Ohio

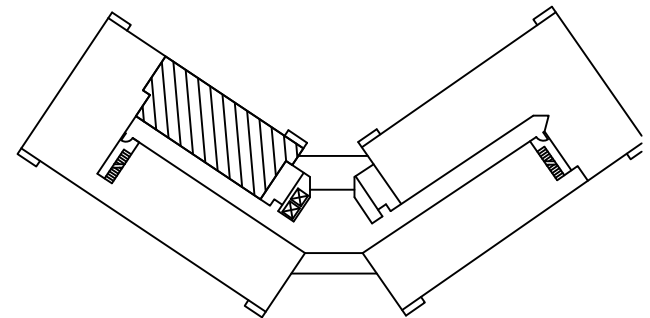

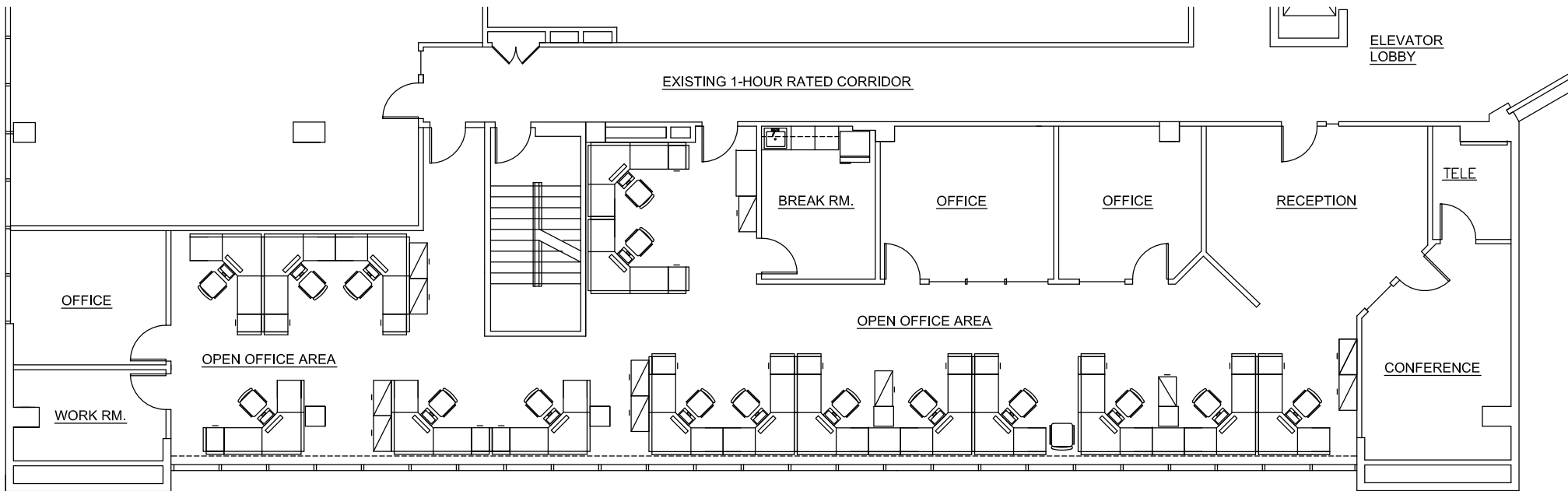

CASCADE I - SUITE 325 MODIS, INC. 3,692 RSF

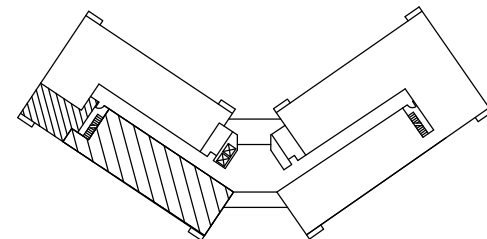



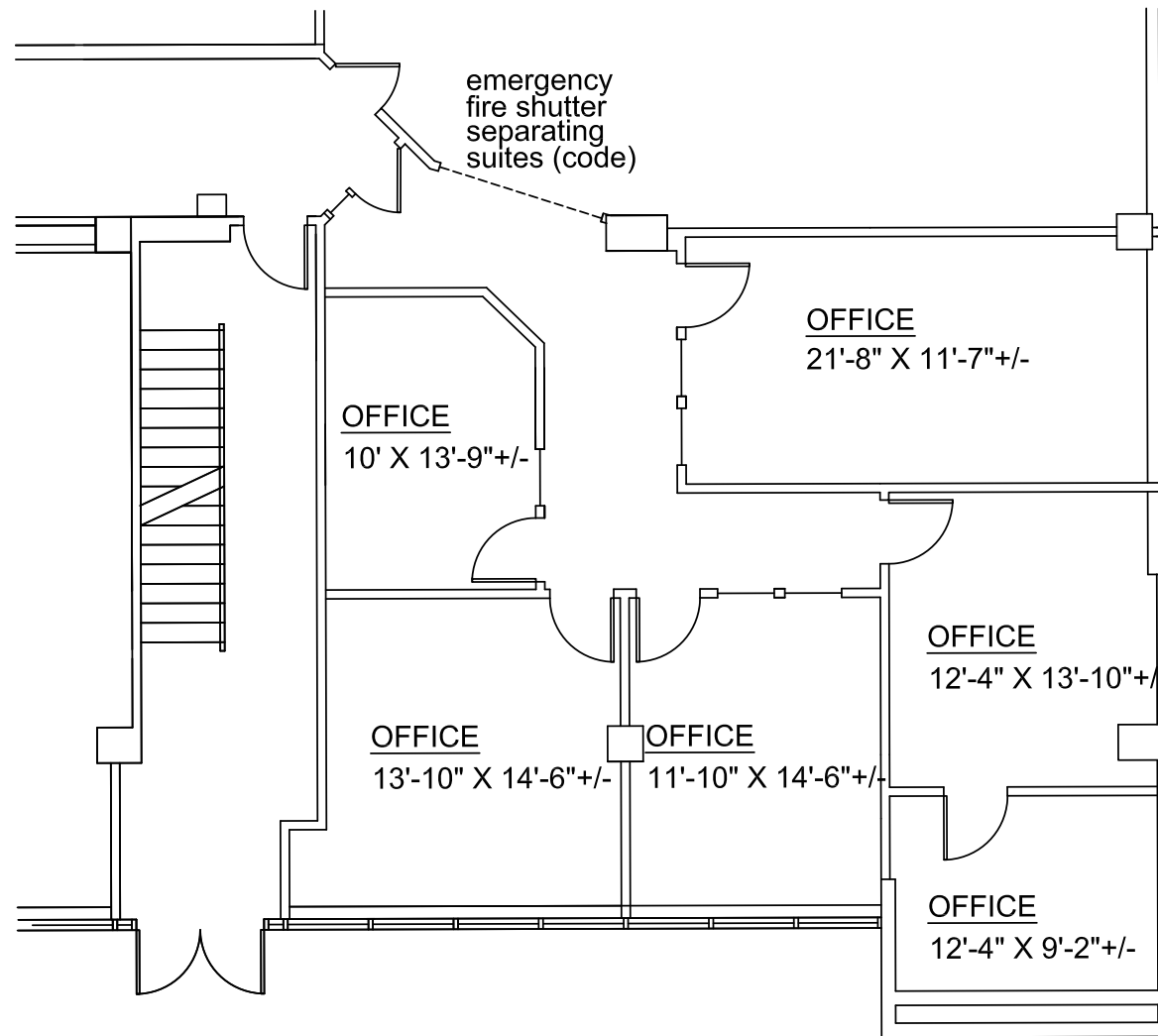

## Cascade II - Suite 120

1,566 Square Feet Available    Scale 1/8" = 1' - 0"

## Cascade Corporate Center

150 East Wilson Bridge Road - First Floor  
Worthington, Ohio

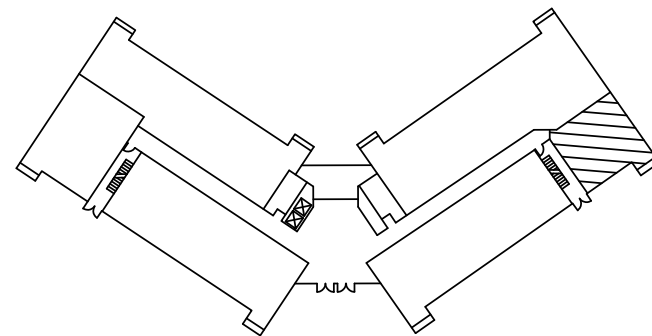

First Floor Key Plan

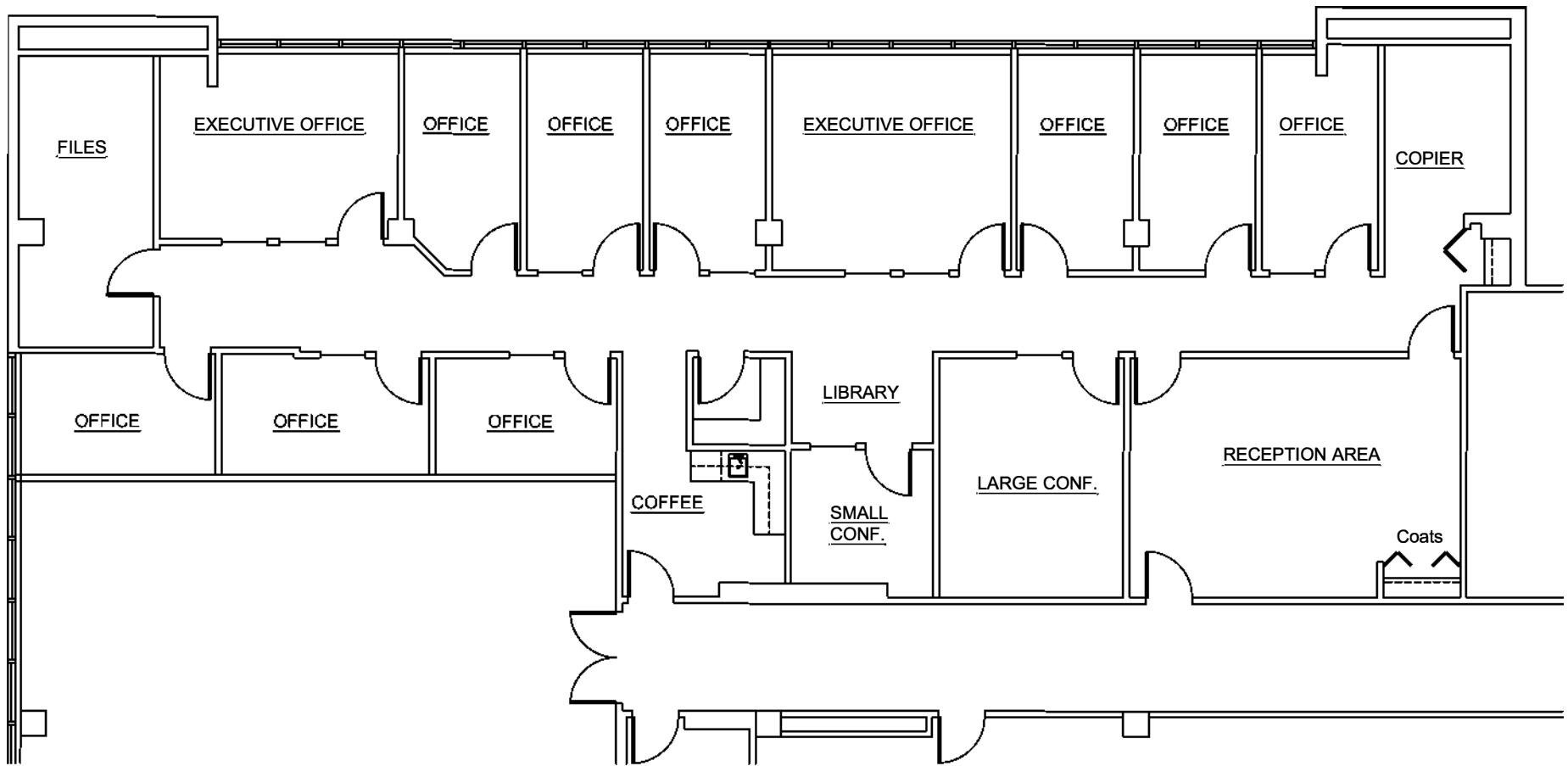

CASCADE II - SUITE 160

3,455 RSF

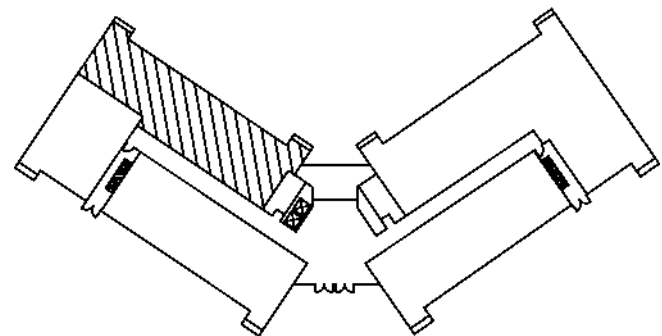

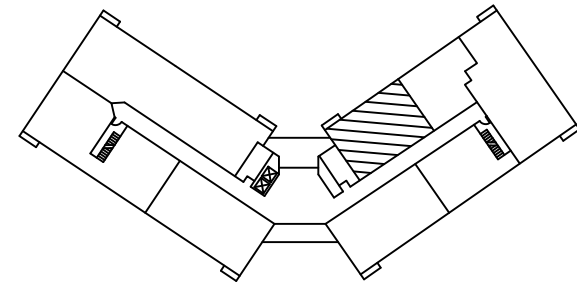
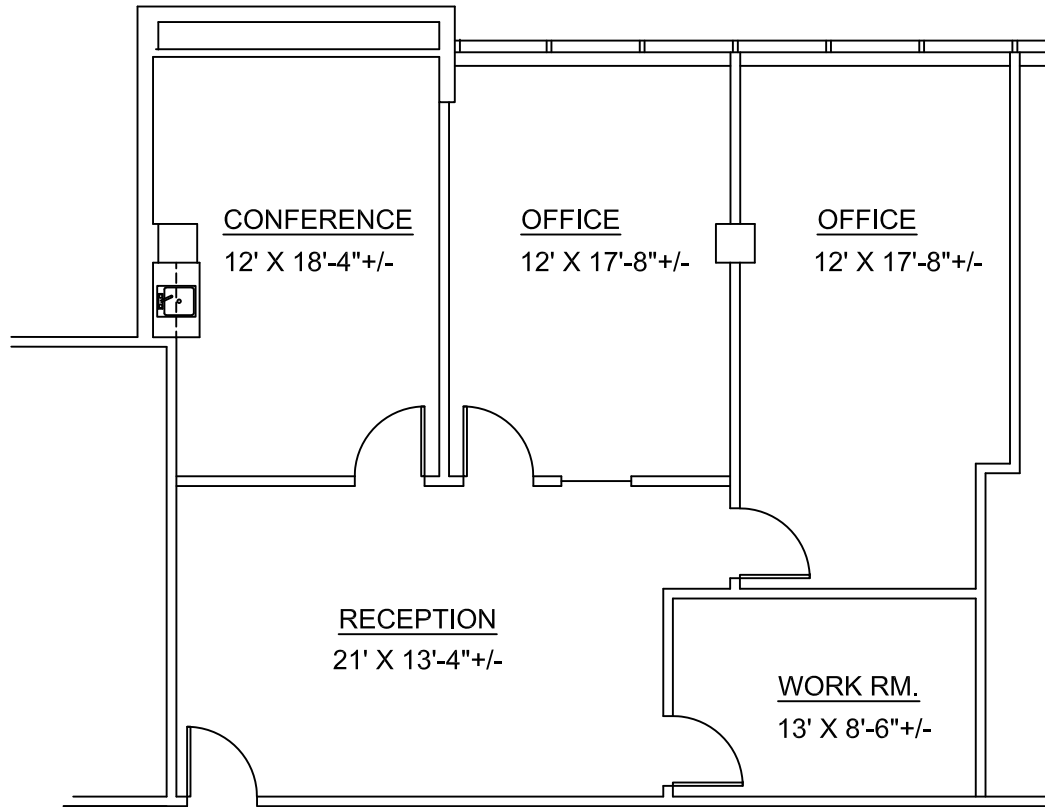

Second Floor Key Plan

## Cascade II - Suite 210

1,373 Sq. Ft.    Scale 1/8" = 1' - 0"

## Cascade Corporate Center

150 East Wilson Bridge Road - Second Floor  
Worthington, Ohio

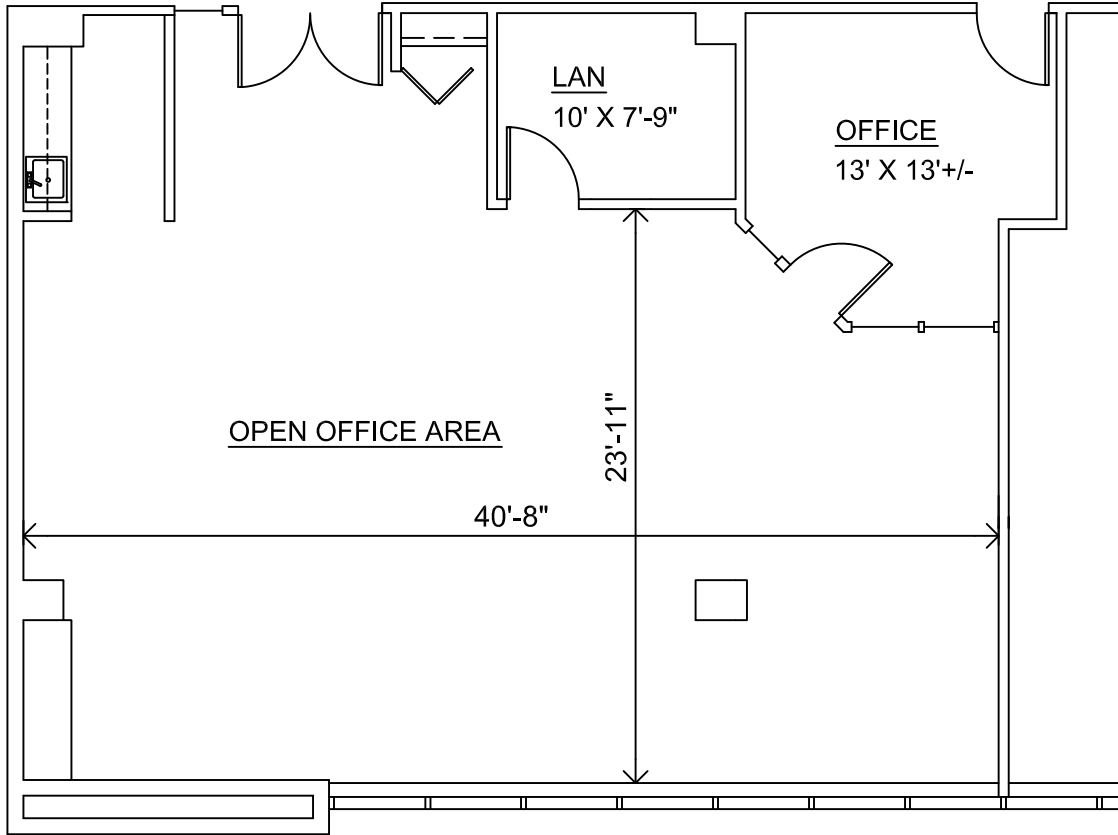

# Cascade II - Suite 235

1,536 Sq. Ft.    Scale 1/8" = 1' - 0"

## Cascade Corporate Center

150 East Wilson Bridge Road - Second Floor  
 Worthington, Ohio

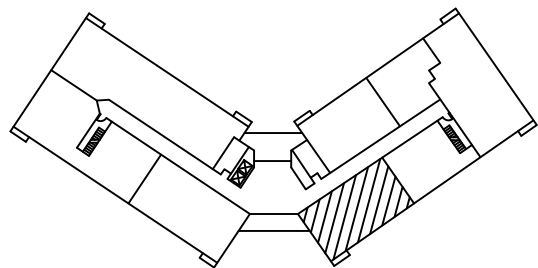

Second Floor Key Plan

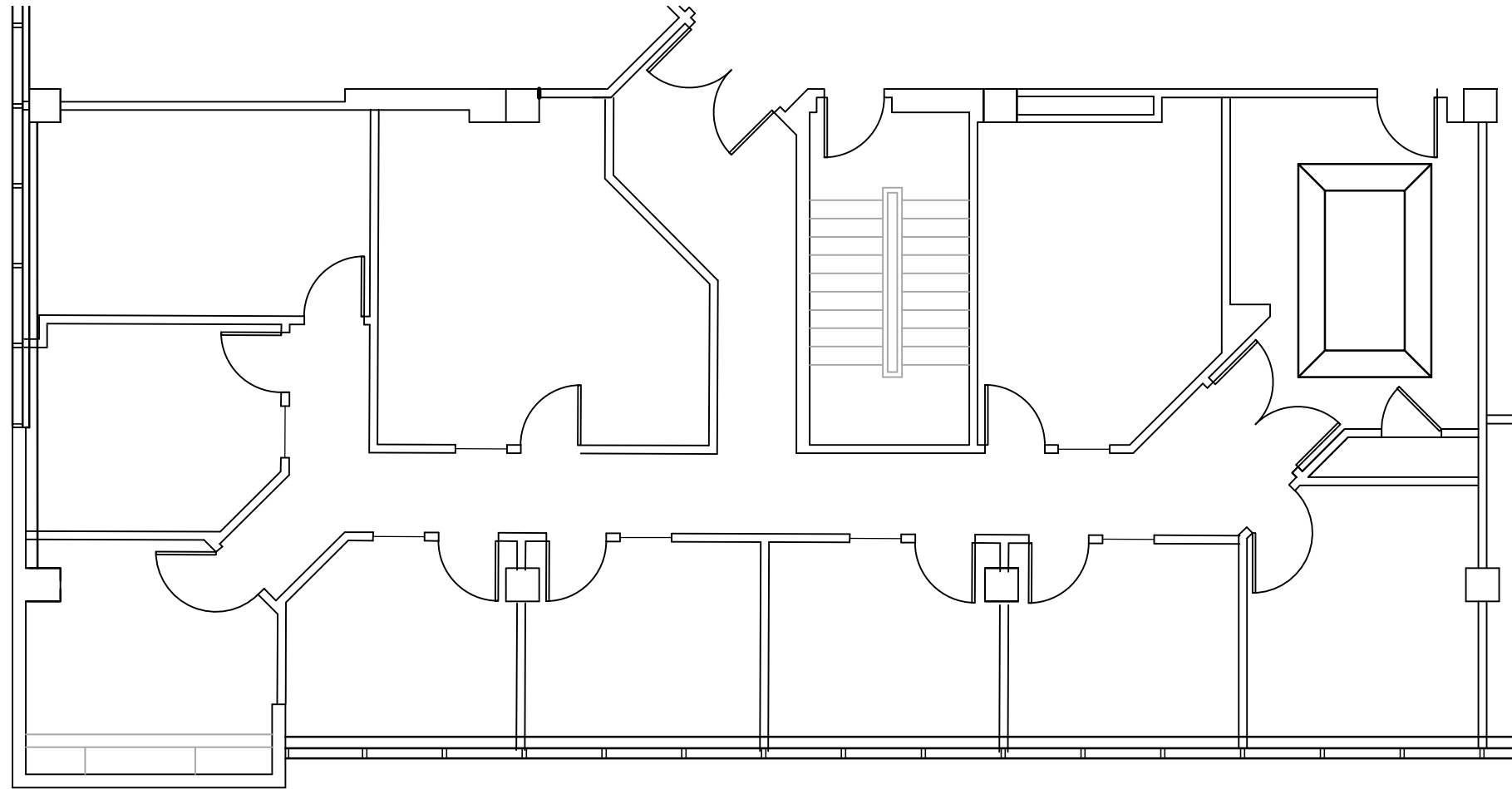

Suite 250

2,591 SF

1/8" = 1'-0"

Cascades II - 4,414 SF  
Suite 320

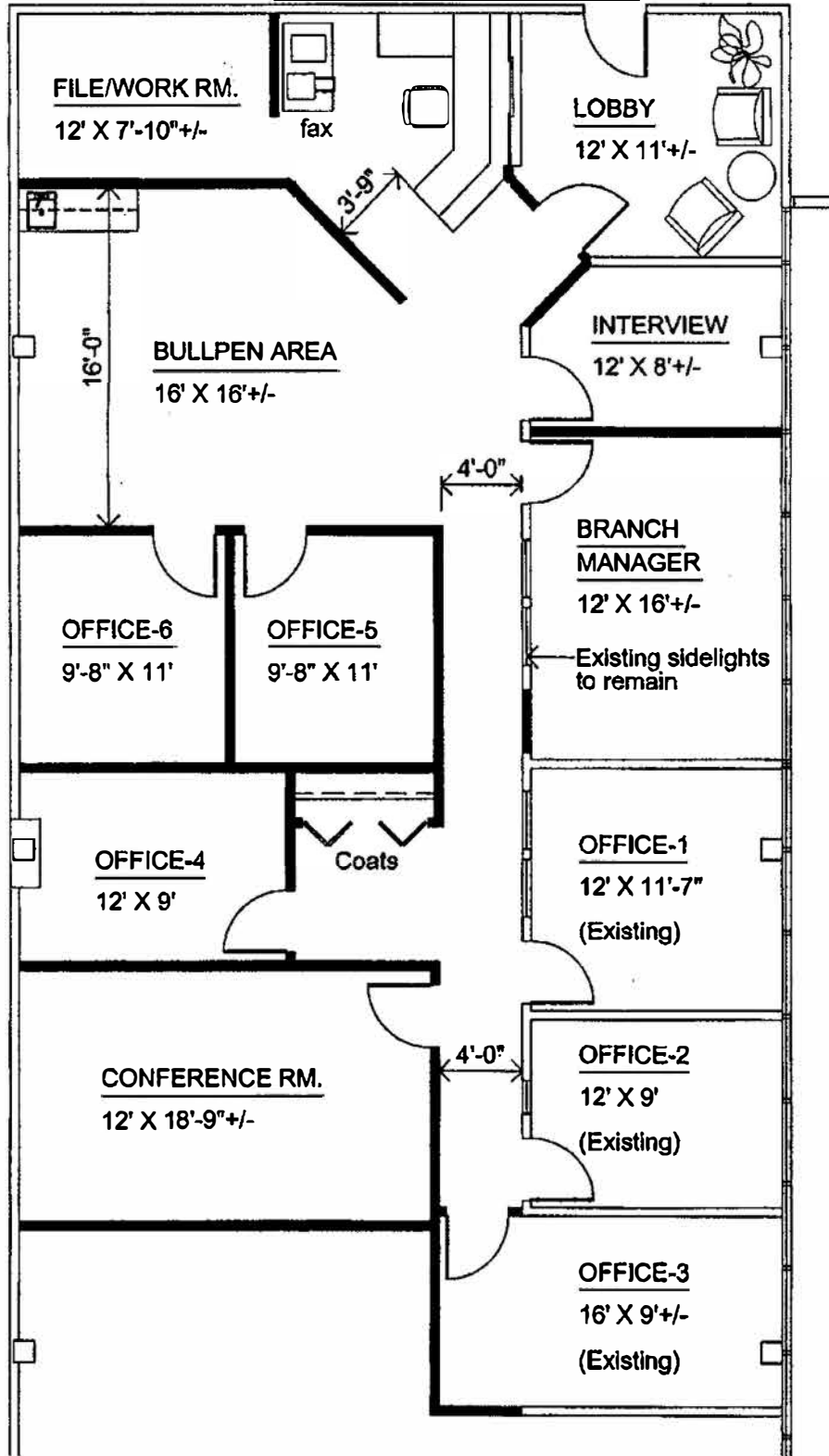

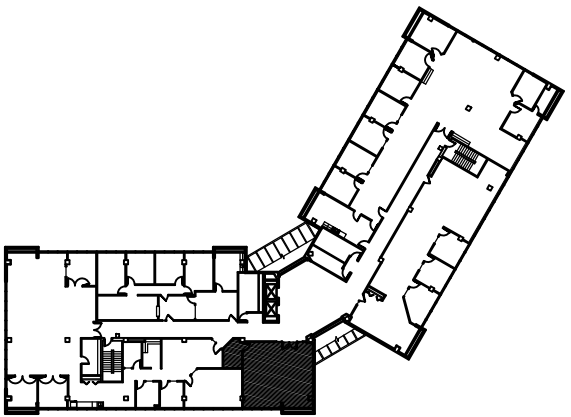
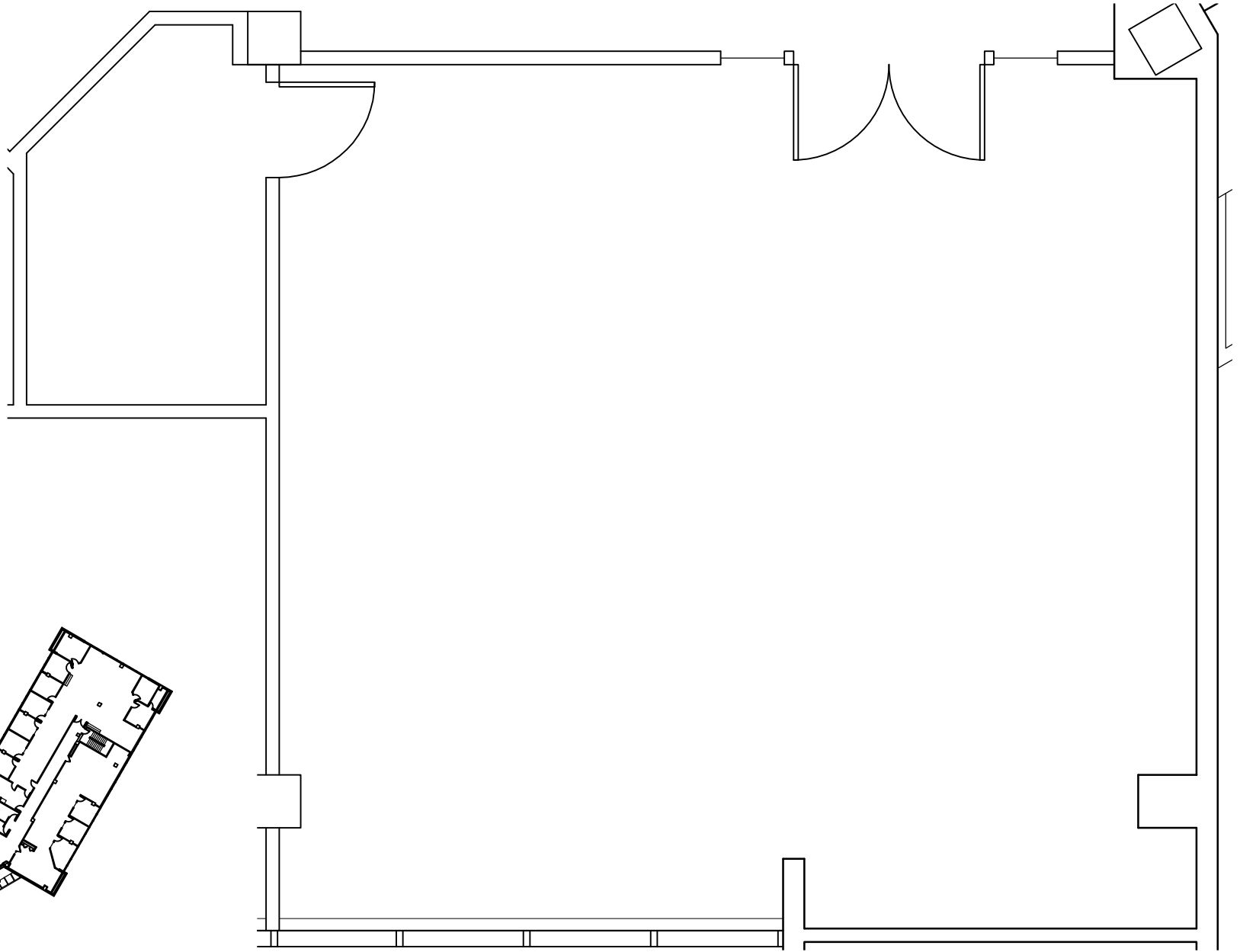

N building key plan

Third Floor

N.T.S.

# Suite 330

150 E Wilson Bridge Road - Cascade II

N.T.S.

1,002 RSF.

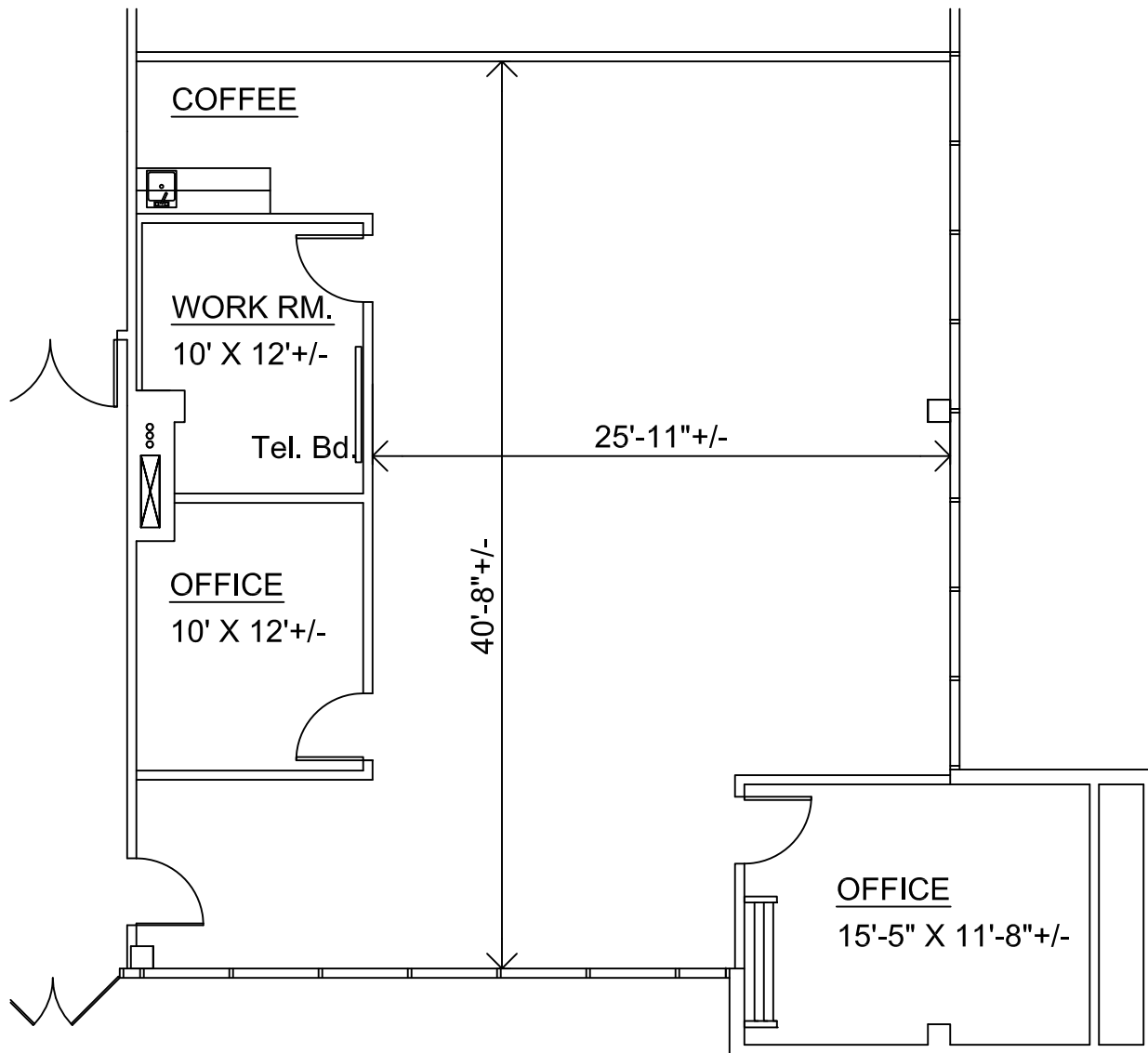

# Cascade V - Suite 130

1,816 Sq. Ft.    Scale 1/8" = 1' - 0"

## Cascade Corporate Center

250 East Wilson Bridge Road - First Floor  
 Worthington, Ohio

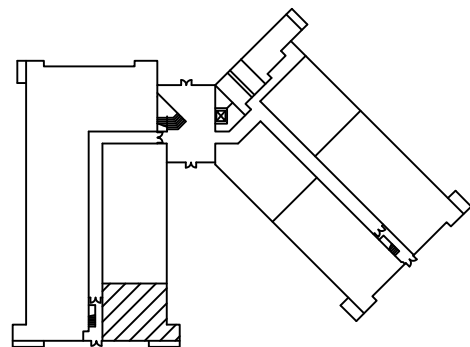

First Floor Key Plan



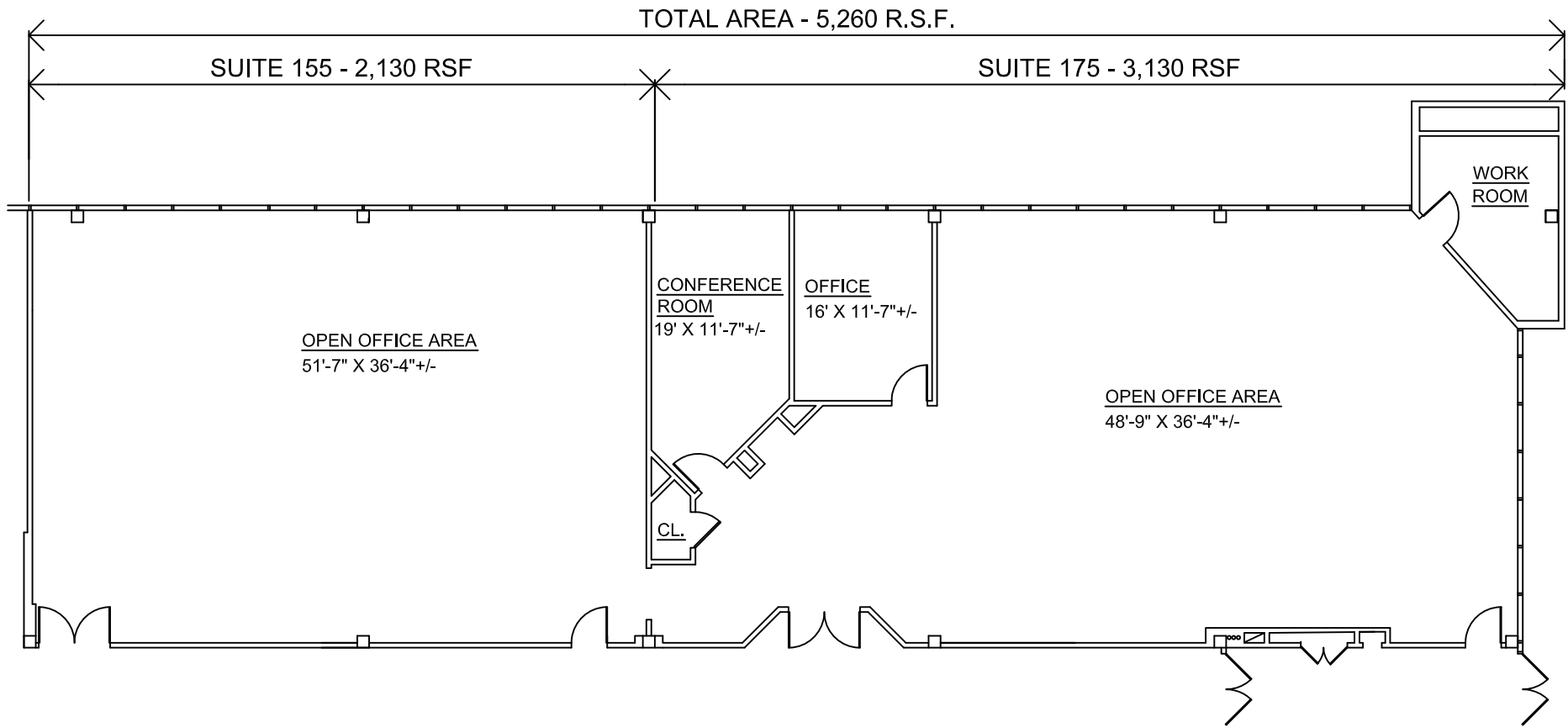

# Cascade V - Suites 155-175

5,260 Sq. Ft. Total Available Not to Scale

## Cascade Corporate Center

250 East Wilson Bridge Road - First Floor  
Worthington, Ohio

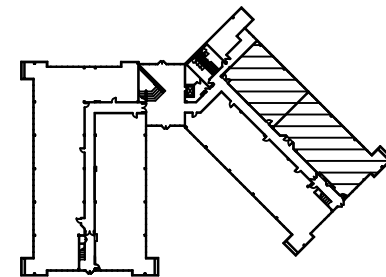

First Floor Key Plan

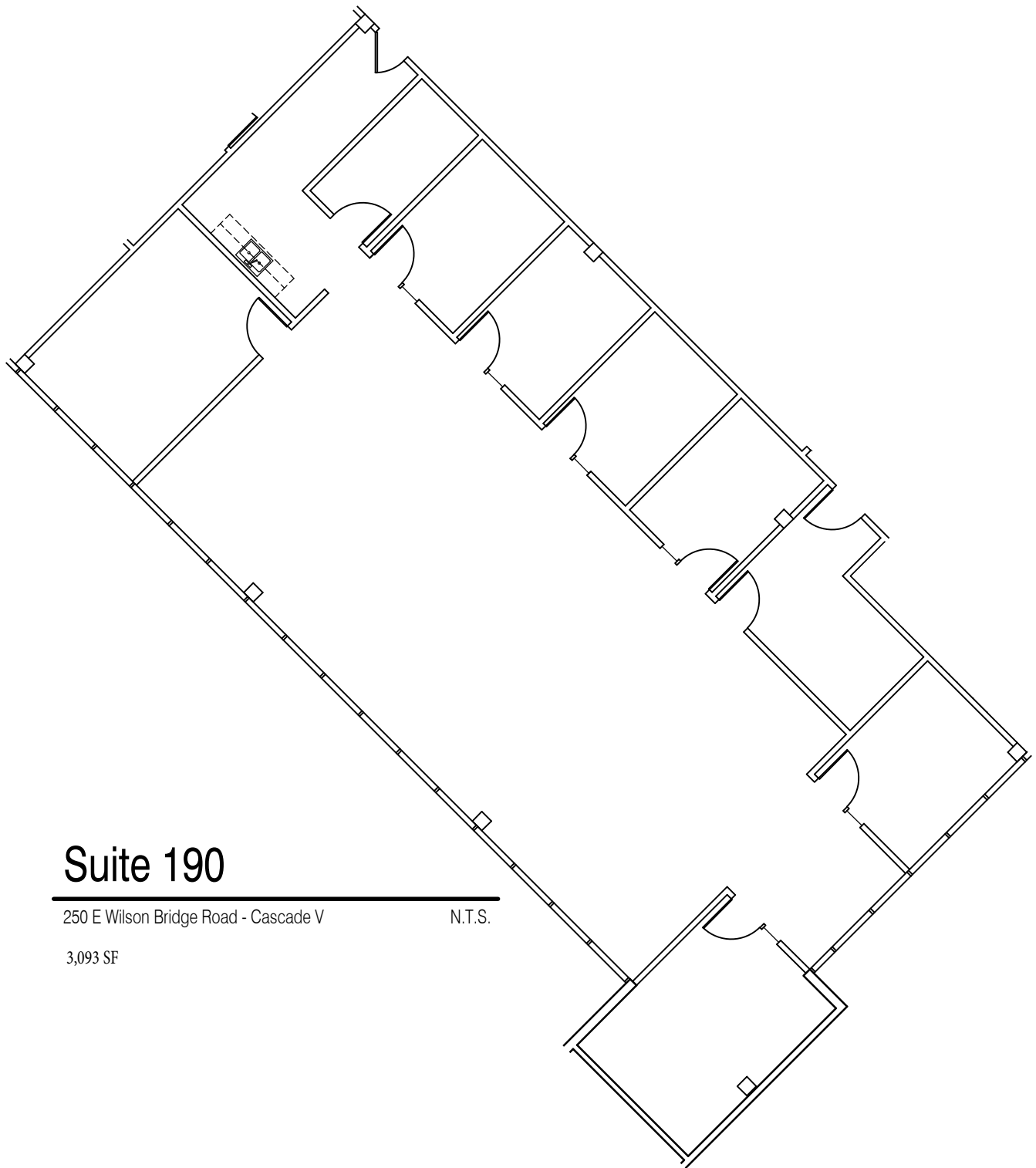

## Suite 190

250 E Wilson Bridge Road - Cascade V

N.T.S.

3,093 SF

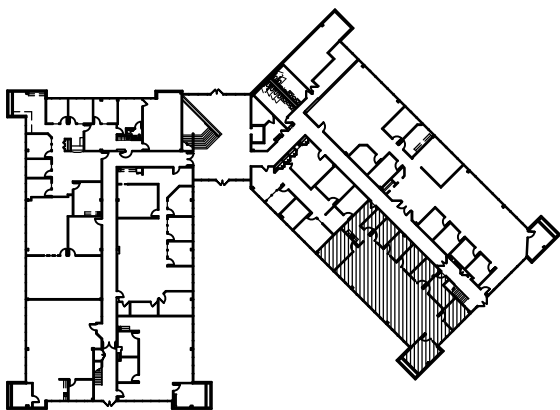

N building key plan

First Floor

N.T.S.

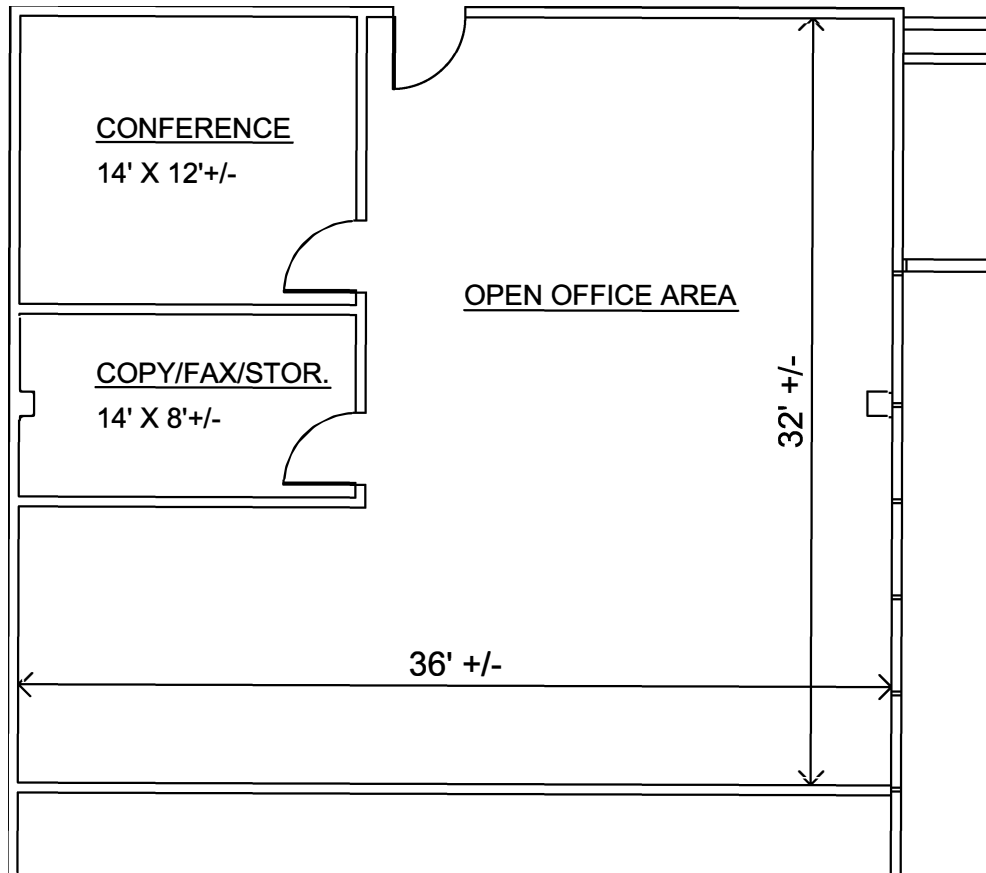

# Cascade V - Suite 210

1,359 Sq. Ft.    Scale 1/8" = 1' - 0"

## Cascade Corporate Center

250 East Wilson Bridge Road - Second Floor  
 Worthington, Ohio

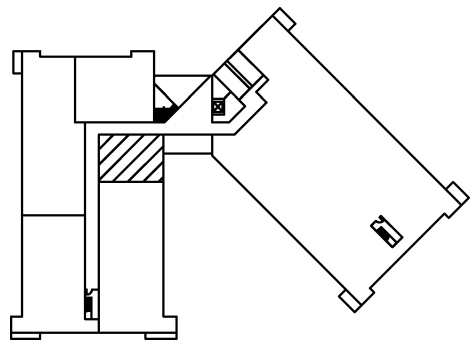

Second Floor Key Plan

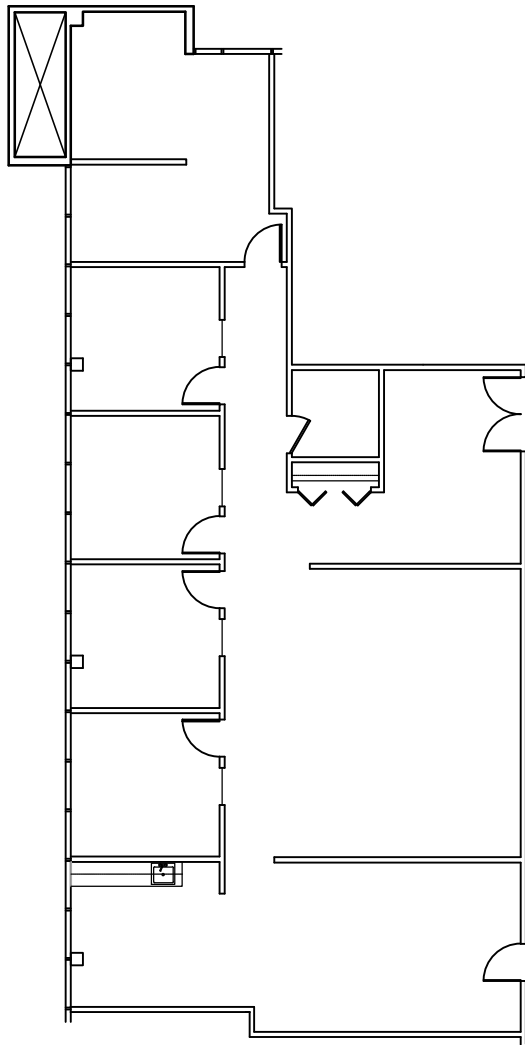

Suite 240  
2,741 Sq. Ft.

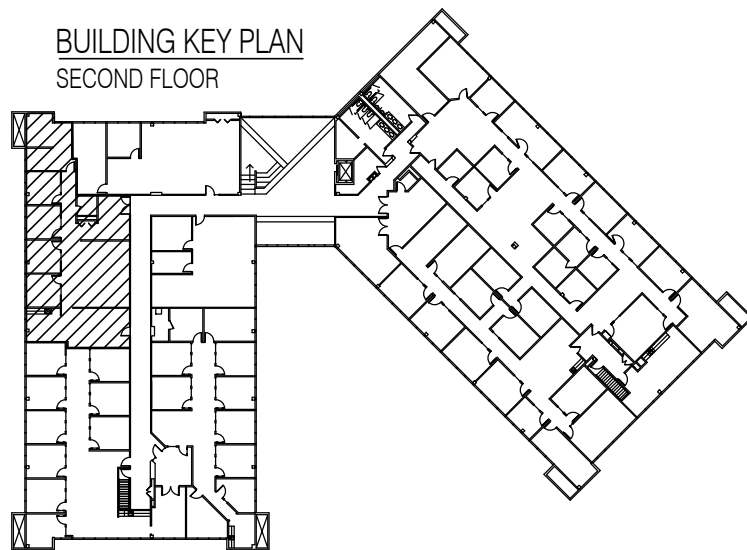

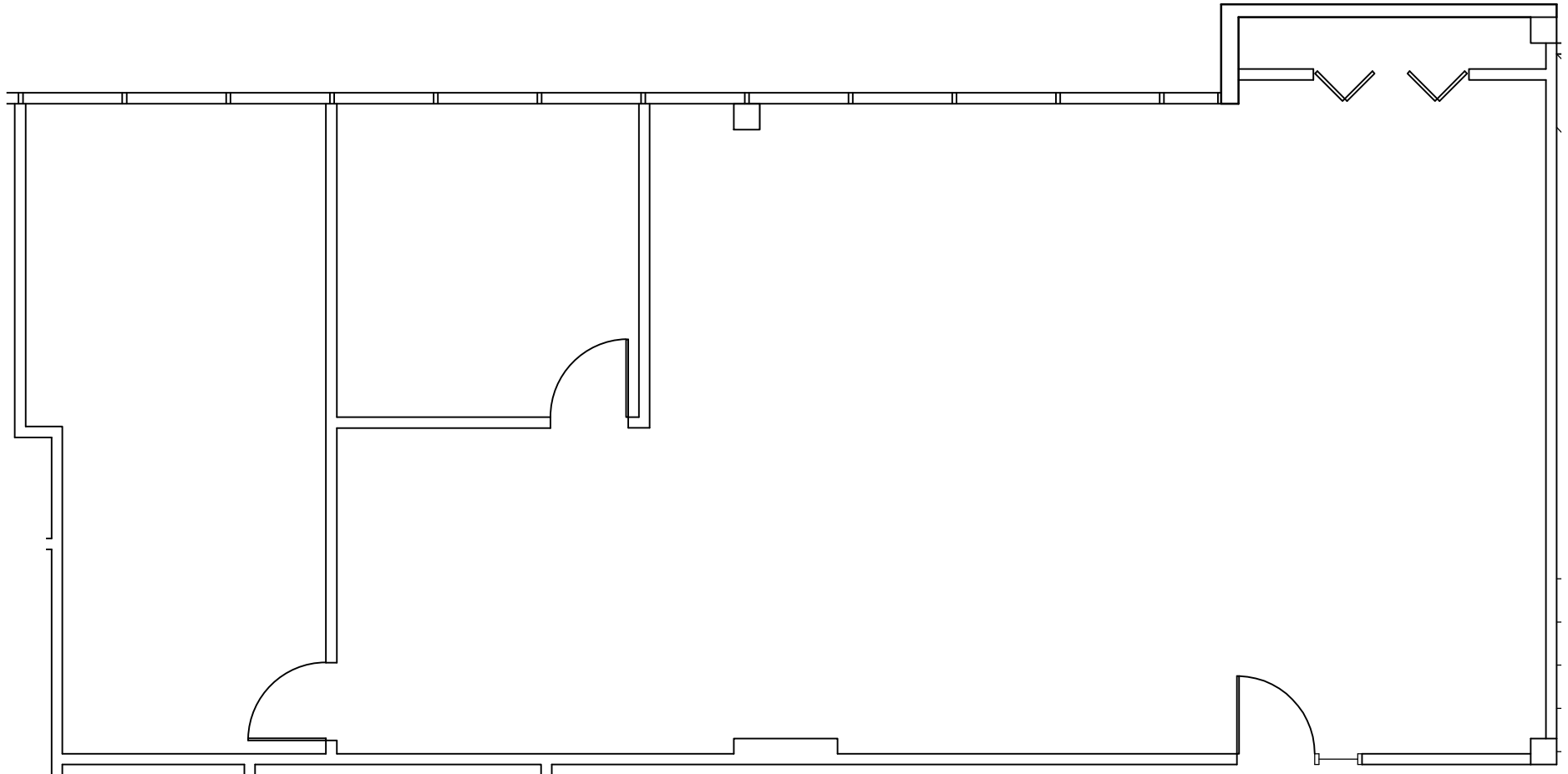

## Suite 270

250 E Wilson Bridge Road - Cascade V

N.T.S.

1,760 R.S.F.

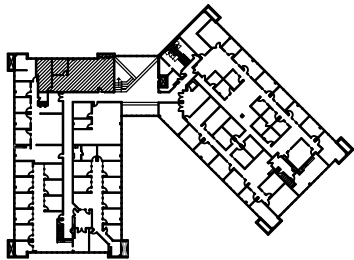

building key plan

Second Floor

N.T.S.



**DARIN RANKER ARCHITECTS**  
+ INTERIOR DESIGNERS  
5925 Wilcox Place, Suite E Dublin, OH 43016  
Ph. 614-792-1002 Fax 614-792-1001  
admin@darinranker.com